

QUANTITATIVO

HATCH	TIPO	ÁREA
[Hatch]	BLOQUETE	1.902,74 m ²
[Hatch]	BRITA	240,03 m ²
[Hatch]	GRAMA	380,62 m ²
	MEIO-FIO	645,47 m

— cercamento 230,00 m
 — Portões 3 un

PLANTA BAIXA DE IMPLANTAÇÃO

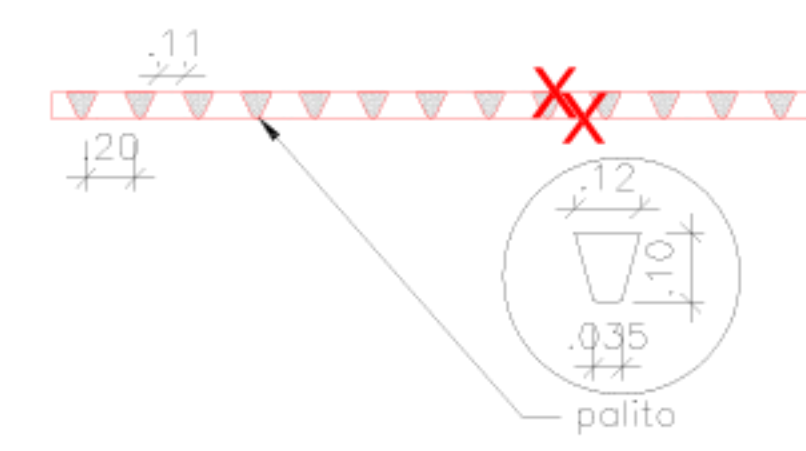
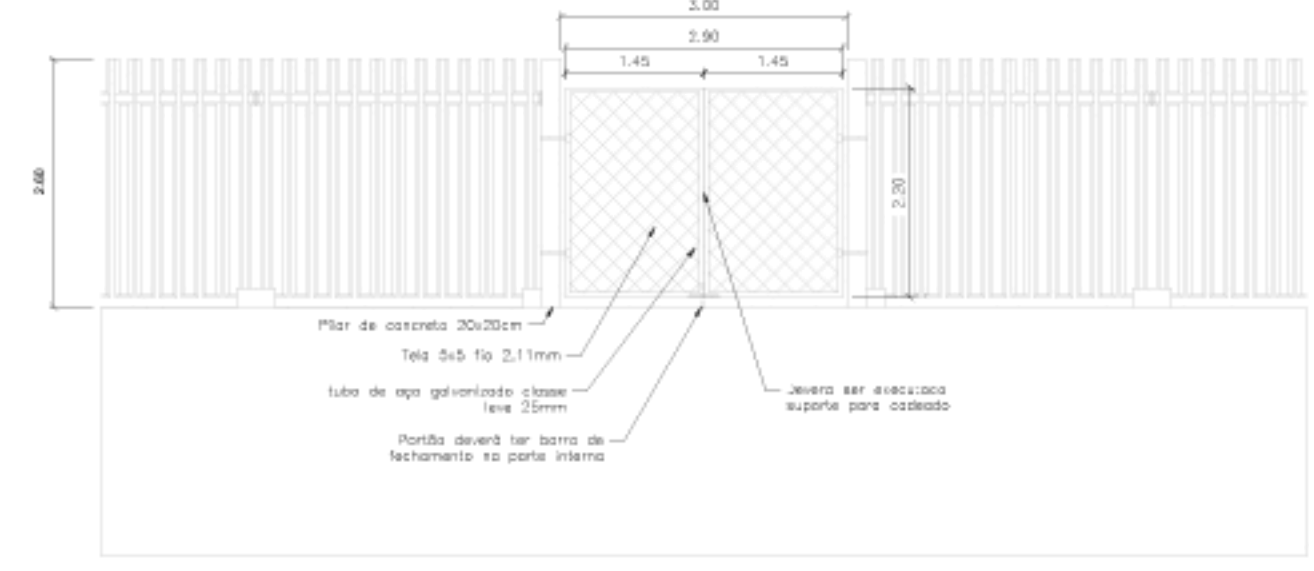
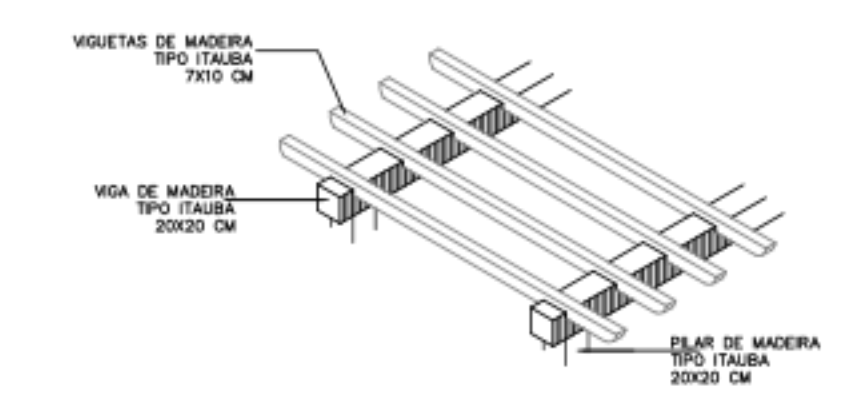
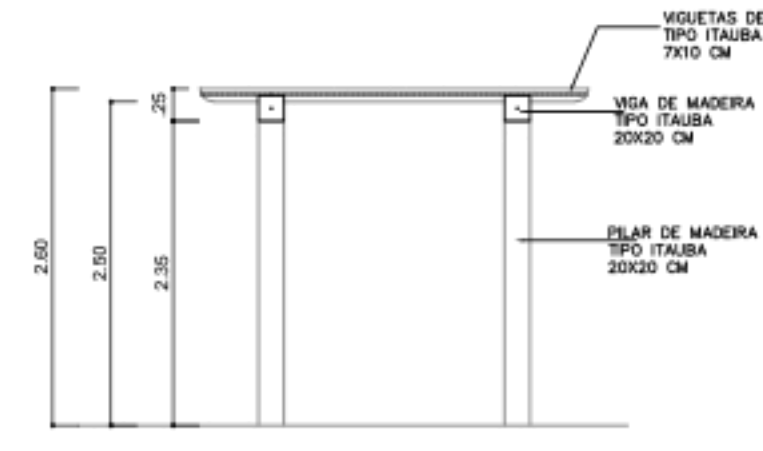
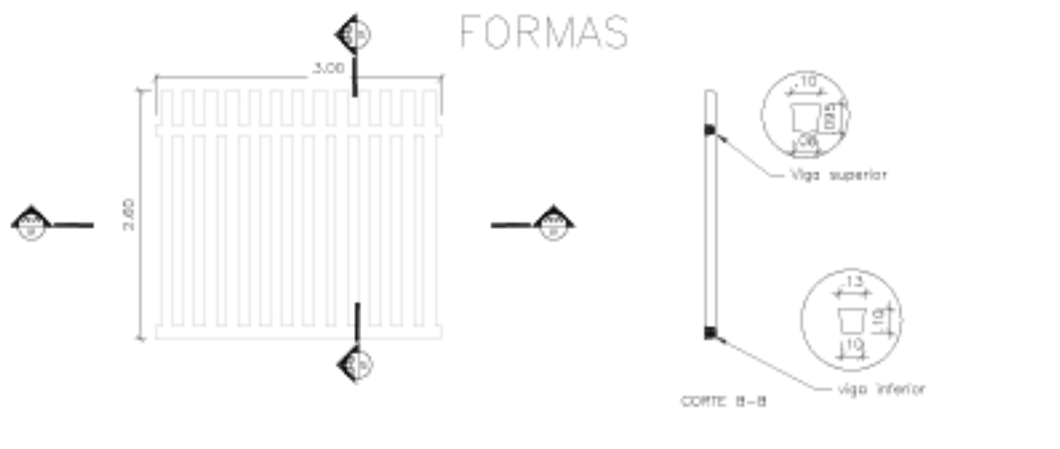
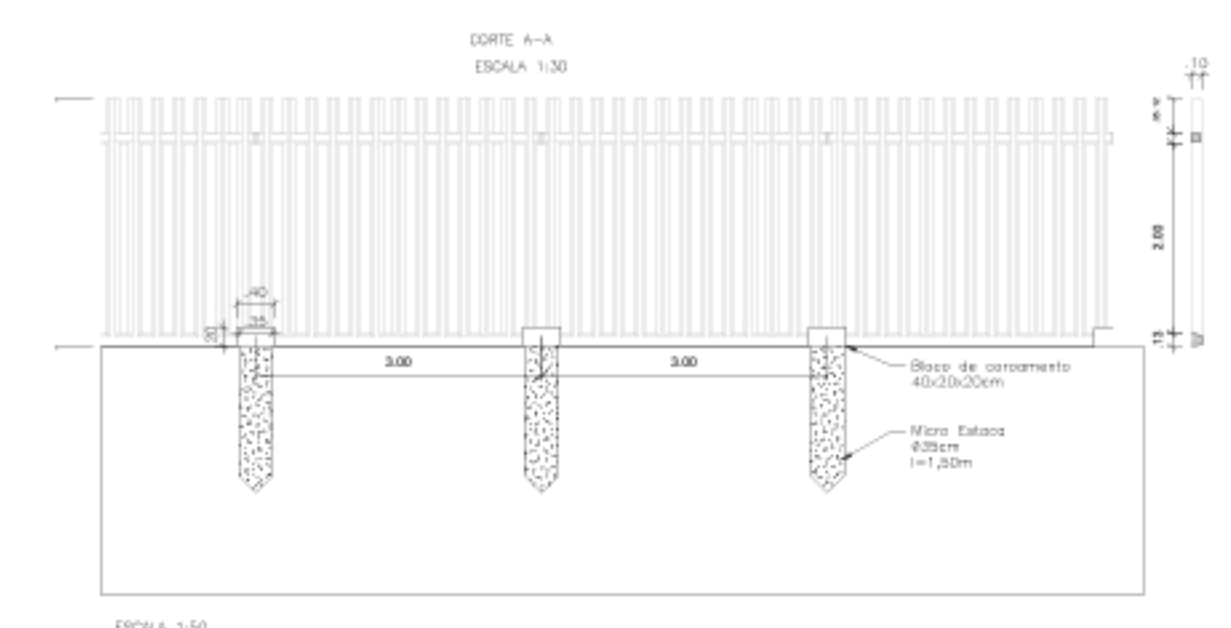
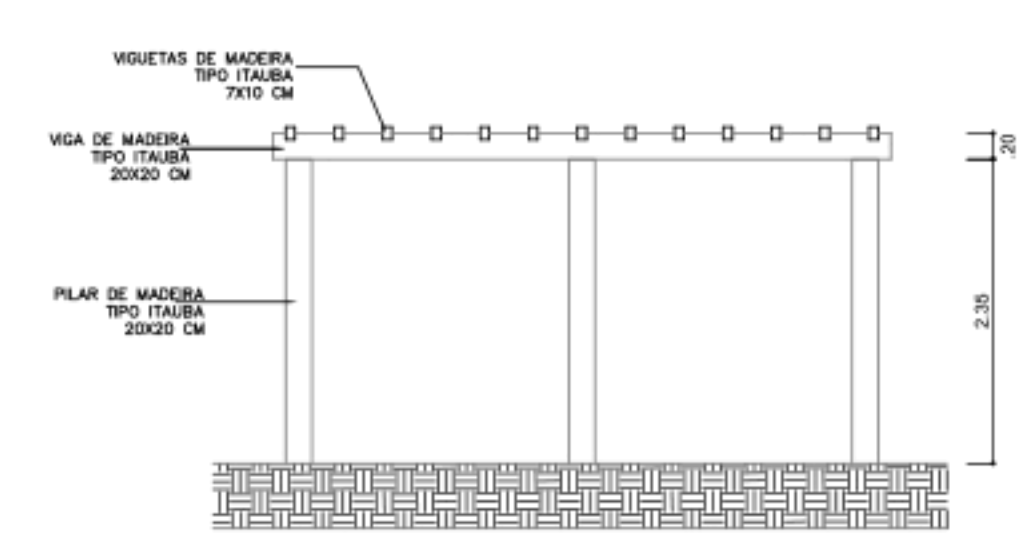
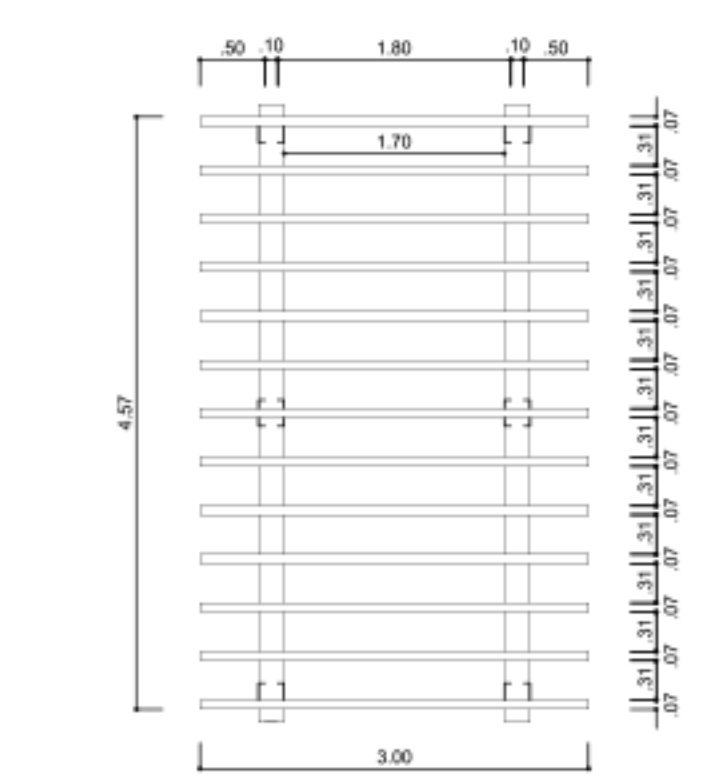

PERGOLADO

CERCA DE CONCRETO

PARQUE NATURAL MUNICIPAL SAINT'HILAIRE

PLANTA BAIXA IMPLANTAÇÃO DA NOVA SEDE

PROJETO: SMAMUS DESENHO: G SOLERA ESCALA(S): 1:150 DATA: 26/08/2022

ARQUITETOS: ALEX SOUZA
 GUILHERME G SOLERA